

Additional Resources	A spreadsheet that calculates the approximate VCO frequency and gives typical worked examples can be downloaded together with this Application Note.
----------------------	--

## 1 Introduction

Some of CML's RF products, including the CMX994, provide an integrated negative resistance amplifier that can be used with external components to create a VCO. Using this integrated amplifier reduces component count, cost and size relative to using an external VCO circuit.

This application note describes how to estimate the operating frequency of VCO designs that use the negative resistance amplifier, taking both discrete component values and some realistic stray capacitances into account.

## 2 History

Version	Changes	Date
1	Initial Version	04-10-13

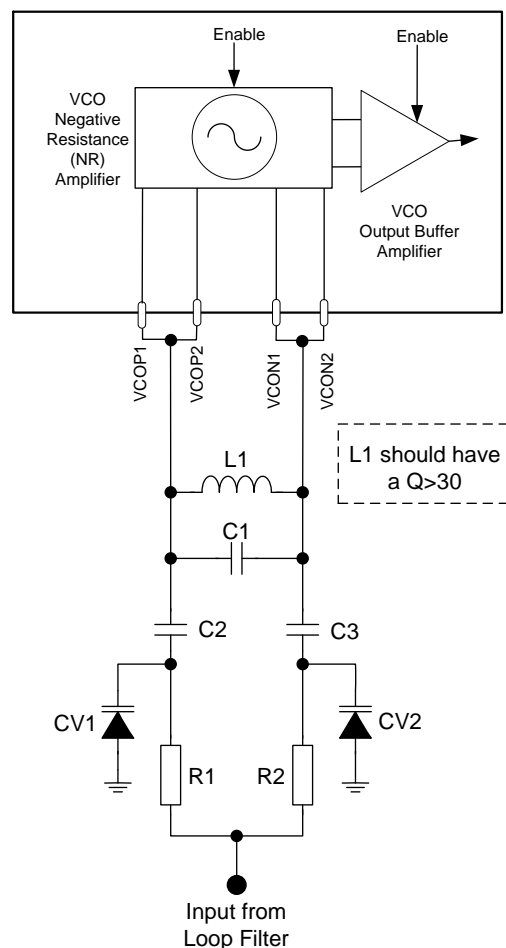

**Figure 1 Example External Components – VCO External Tank Circuit**

L1	8.2 nH (Note 1)	CV1	SMV1705-079LF
C1	8.2 pF (Note 2)	CV2	SMV1705-079LF
C2	22pF	R1	10k $\Omega$
C3	22pF	R2	10k $\Omega$

Note 1: Tolerance of 2% or better recommended

Note 2: Tolerance of 5% or better recommended

**Table 1 Internal VCO Amplifier Tank Circuit for 440MHz Operation**

Figure 1 presents a method of utilising the negative resistance amplifier to create a VCO. There are other ways to configure such a design but the principles are similar. Several factors influence the precise frequency obtained. For example, stray capacitance and inductance plus variation in the negative resistance value with frequency and amplitude. It is usual for some empirical work to be carried out to ensure that a design is nominally centred at the required frequency and has suitable tolerance to allow the required frequency range to be obtained. This note provides initial guidance to get reasonably close to the required operation. It is assumed that the basic concepts of a varactor-controlled VCO are understood, otherwise the theory is available from many text books.

Four pins are used in the design to reduce the effects of the package internal inductance that can otherwise restrict the maximum operating frequency. VCOP1 and VCOP2 are the positive pair, VCON1 and VCON2 are the negative pair. The tank inductor should be placed as close as possible to these package pins. Note: for recommendations on PCB layout see the device datasheet.

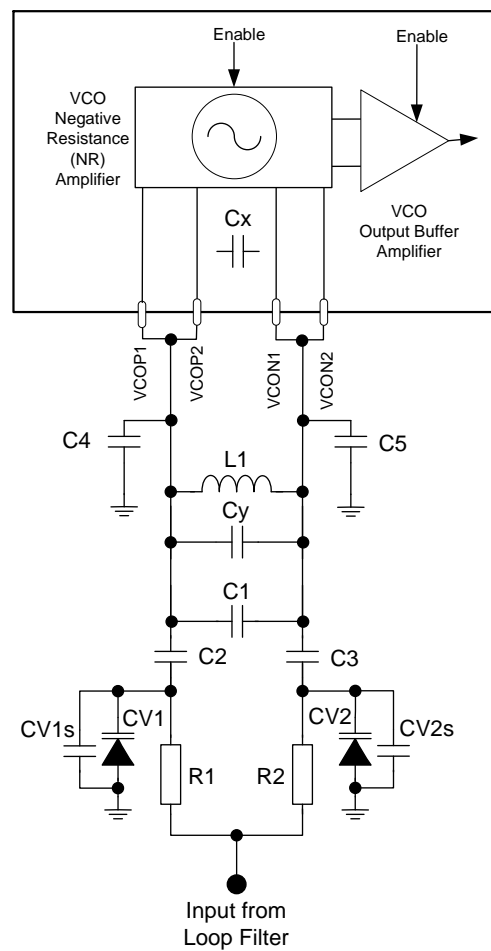

**Figure 2 VCO External Components (showing stray components)**

Figure 2 shows the VCO configuration with extra capacitors representing unavoidable strays. It is necessary to estimate these stray capacitor values to get close to the required centre operating frequency. Typical example values are given in Table 2.  $L_1$  may also add additional stray series inductance depending on the board layout. This should be added to  $L_1$ 's value.

Ref Designator	Description	Nominal Value
Cx	Internal chip capacitance	1.8pF
Cy	Parallel capacitance of L1	0.3pF
C4, C5	Capacitance of circuit board tracks from CMX994 to L1	2pF
CV1, CV2	Varactor capacitances	13pF
CV1s, CV2s	Lumped stray circuit board capacitance on each varactor	1pF
C2, C3	Series coupling capacitances	22pF
C1	Main tank capacitor	8.2pF
L1	Main tank inductance	8.2nH

**Table 2 Nominal Discrete and Stray Component Values**

The resulting VCO nominal operating frequency (f) is given by:

$$f = \frac{1}{2\pi\sqrt{LC}}$$

Where L= L1 and C is given by:

$$C = C1 + Cx + Cy + \left( \frac{1}{CV1+CV1s} + \frac{1}{CV2+CV2s} + \frac{1}{C2} + \frac{1}{C3} \right)^{-1} + \left( \frac{1}{C4} + \frac{1}{C5} \right)^{-1}$$

Using the values of Table 2 yields an estimated nominal frequency (f) of 445MHz for Figure 2.

An Excel spreadsheet that helps with choosing component values can be downloaded together with this Application Note. It should be noted that the stray components can have a significant impact on the frequency obtained, especially at higher frequencies, and accurate estimation is not always easy to do. As a result, some experimentation may be required. Examples are given in the spreadsheet including some based on CML's evaluation boards. Note that in these boards there is an additional stray series inductance of about 0.5nH.

CML does not assume any responsibility for the use of any algorithms, methods or circuitry described. No IPR or circuit patent licenses are implied. CML reserves the right at any time without notice to change the said algorithms, methods and circuitry and this product specification. CML has a policy of testing every product shipped using calibrated test equipment to ensure compliance with this product specification. Specific testing of all circuit parameters is not necessarily performed.

 <b>CML Microcircuits (UK) Ltd</b> <small>COMMUNICATION SEMICONDUCTORS</small>	 <b>CML Microcircuits (USA) Inc.</b> <small>COMMUNICATION SEMICONDUCTORS</small>	 <b>CML Microcircuits (Singapore) Pte Ltd</b> <small>COMMUNICATION SEMICONDUCTORS</small>
<b>Tel:</b> +44 (0)1621 875500 <b>Fax:</b> +44 (0)1621 875600 <b>Sales:</b> sales@cmlmicro.com  <b>Tech Support:</b> techsupport@cmlmicro.com	<b>Tel:</b> +1 336 744 5050 800 638 5577 <b>Fax:</b> +1 336 744 5054 <b>Sales:</b> us.sales@cmlmicro.com <b>Tech Support:</b> us.techsupport@cmlmicro.com	<b>Tel:</b> +65 62 888129 <b>Fax:</b> +65 62 888230 <b>Sales:</b> sg.sales@cmlmicro.com  <b>Tech Support:</b> sg.techsupport@cmlmicro.com
<b>- www.cmlmicro.com -</b>		